

# UNIP

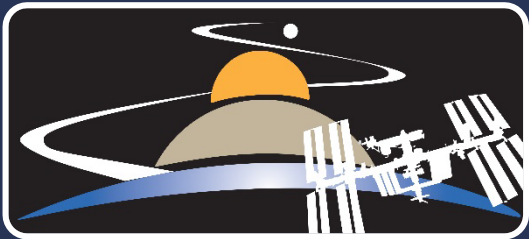

## Structures and Thermal Subsystem



**Exploration Research and  
Technology Programs**





# Structures

# UNP What is it?



- Physical structure of the satellite
- Responsible for creating a structure that fits and fastens all avionics and hardware.
- Requirements are related to:
  - LV safety, strength, rigidity, life, mounting, envelope, venting, alignment/tolerances
- During mission concepting, form factor (e.g. 3U, 6U, 12U) should be known
- In Baseline Design, the structural frame should be developed
  - Start with a CAD model and have basic primitives (boxes) as stand-ins
  - Update model as avionics mature

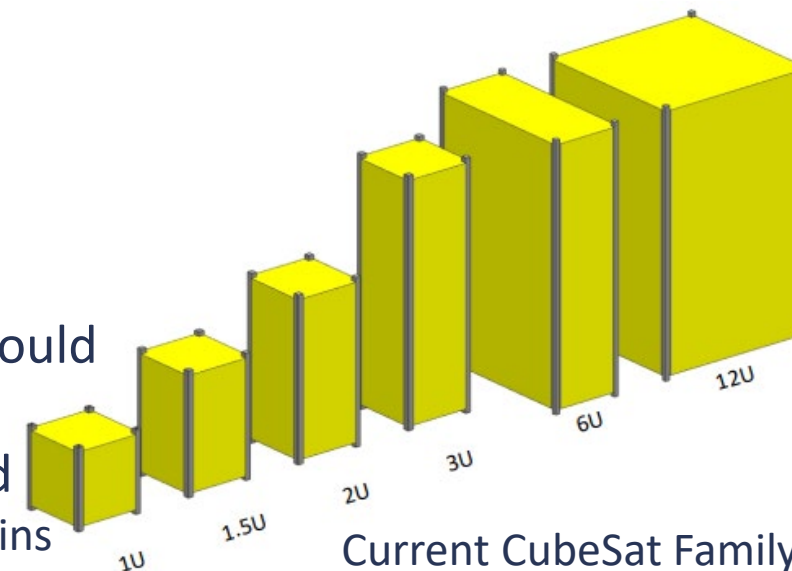

[https://static1.squarespace.com/static/5418c831e4b0fa4ecac1bacd/t/62193b7fc9e72e0053f00910/1645820809779/CDS+REV14\\_1+2022-02-09.pdf](https://static1.squarespace.com/static/5418c831e4b0fa4ecac1bacd/t/62193b7fc9e72e0053f00910/1645820809779/CDS+REV14_1+2022-02-09.pdf)

UNP1: The CubeSat shall be designed to withstand the launch and on-orbit environments of the launch vehicle without **failure** that results in damage of the launch vehicle and its contents or failure that causes injury to ground handling crew

# UNP Types of CubeSat Structures



- Rail Mounted
  - Smooth rails along 4 edges of the CubeSat
  - Rails interface with dispenser preventing rotation and movement. Loose fit allows CubeSat to rattle
  - Most widely used dispenser type
- Tab Mounted
  - Tabs on the bottom/base plate that run the length of the CubeSat
  - Dispenser clamps tabs for rigid interface
  - Planetary Systems Corp (PSC), owned by RocketLabs, holds the patent for this so it's not as widely manufactured
- Tab and Rail types are not cross compatible. Many, but not all, rail types are cross compatible

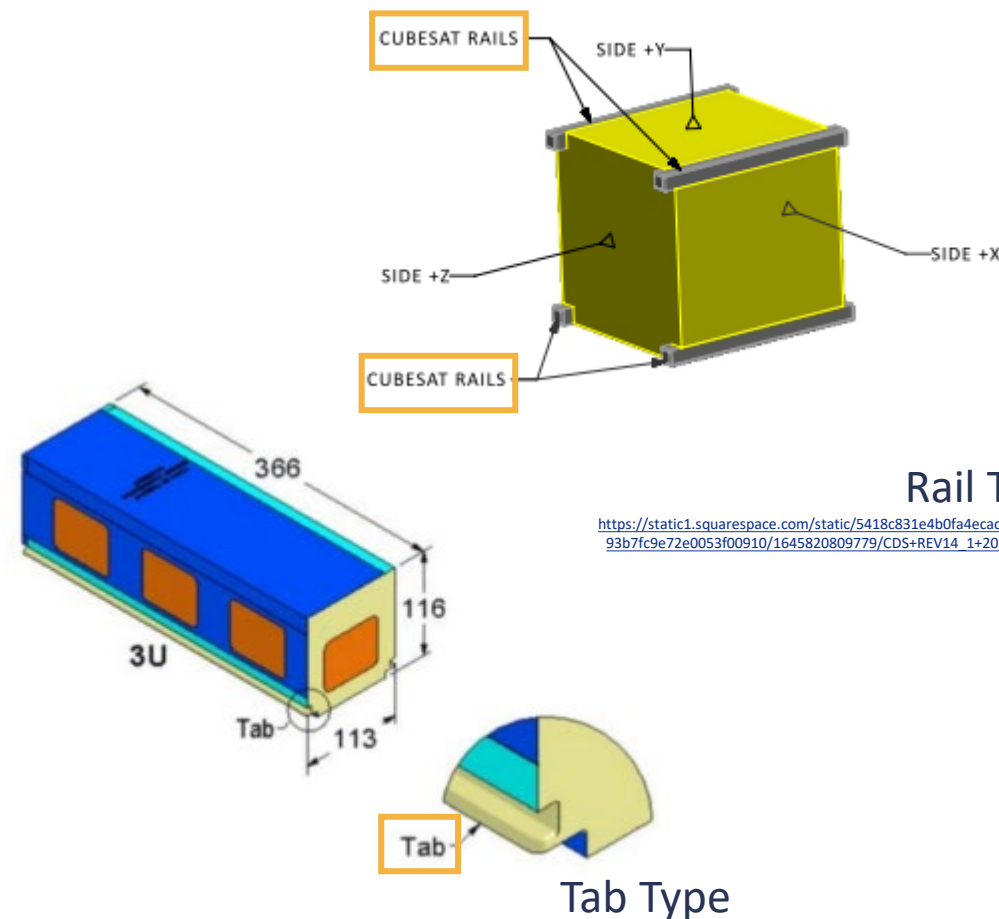

<https://www.rocketlabusa.com/assets/Uploads/PSC/Rocket%20Lab%20PSC%20202002367F%20Payload%20Spec%20for%203U%206U%2012U.pdf>

# UNP Dispenser Types

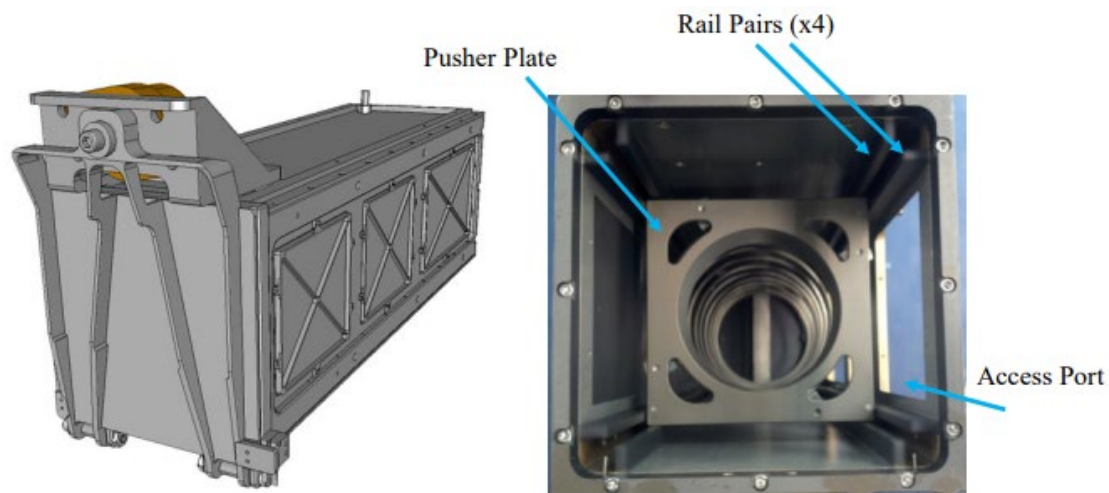

Poly Picosatellite Orbital Deployer (P-POD) Dispenser, Rail Type

[https://static1.squarespace.com/static/5418c831e4b0fa4ecac1bacd/t/62193b7fc9e72e0053f00910/1645820809779/CDS+REV14\\_1+2022-02-09.pdf](https://static1.squarespace.com/static/5418c831e4b0fa4ecac1bacd/t/62193b7fc9e72e0053f00910/1645820809779/CDS+REV14_1+2022-02-09.pdf)

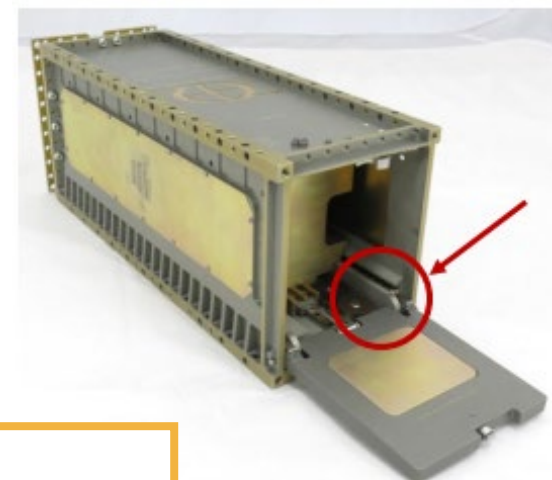

Planetary Systems Corp (PSC) Dispenser, Tab Type

[https://static1.squarespace.com/static/5418c831e4b0fa4ecac1bacd/t/62193b7fc9e72e0053f00910/1645820809779/CDS+REV14\\_1+2022-02-09.pdf](https://static1.squarespace.com/static/5418c831e4b0fa4ecac1bacd/t/62193b7fc9e72e0053f00910/1645820809779/CDS+REV14_1+2022-02-09.pdf)

UNP2: Design to meet requirements specified in the CalPoly CubeSat Design Specifications

# UNP Common Dispenser Types



Rail Mounted

- CalPoly P-POD (3U)
  - CubeSat Design Specification Document Rev. 13
  - Poly Picosatellite Orbital Deployer Mk. III Rev. E User Guide
  - <https://www.cubesat.org/>
- Tyvak Nanosatellite Launch Adapter System (NLAS) (3U / 6U)
  - Tyvak Nanosatellite Launch Adapter System (NLAS) Mk. II User Guide (TK-NLASUGRev1)
  - <https://terranorbital.com/>
- Nanoracks CubeSat Deployer (NRCSD) (3U / 6U [1x6])
  - NanoRacks CubeSat Deployer (NRCSD) Interface Definition Doc't (IDD), NR-NRCSD-S0003, Rev -, 29May2018
  - <https://nanoracks.com/>

Tab Mounted

- Planetary Systems Corporation Canisterized Satellite Dispenser (PSC CSD) (3U / 6U / 12U)
  - Payload Specification Document, PSC 2002367F, 6Aug2018
  - Canisterized Satellite Dispenser (CSD) Data Sheet, 2002337F, 3Aug2018
  - <https://rocketlabusa.com/>

# UNP Deployment of Satellite



Satellite is spring loaded into the dispenser

When it deploys, the satellite will have a velocity/tipoff rate

Good thing to consider for CONOPS for detumble and trying to acquire first contact with your satellite in space

Ejection velocity is approximated using the timing of the two limit switch activations



PSC 6U Dispenser Test

<https://www.youtube.com/watch?v=MjgPA7OvsVY>

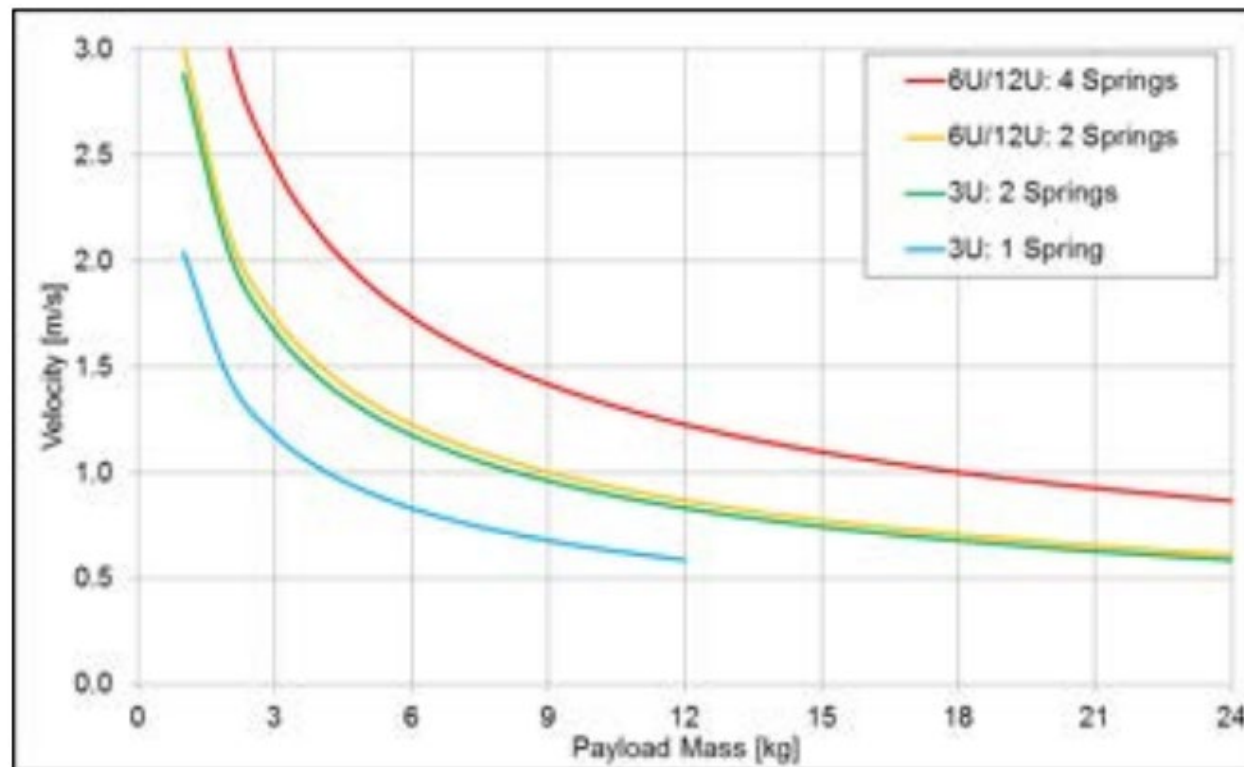

<https://www.rocketlabusa.com/assets/Uploads/2002337G-CSD-Data-Sheet-compressed.pdf>

PSC's Estimated Payload Ejection Velocity



# Requirements

# UNP Requirements Overview



- Fundamental STR parameters
  - Volume: “Do all components fit in the structure?”
  - Deployer: “Does the structure fit in the deployer?”, “Does it meet all deployer tolerance requirements?”, “Can I electrically access the satellite in the deployer?”
  - Safety: “Will the satellite survive the launch vehicle loads?”, “Does the satellite meet outgassing requirements?”
- Drivers:
  - All subsystems: Are the components and connectors oriented sensibly? Are there deployables (i.e. solar panels, magnetometer, antennas)?
  - Power: Is the structure big enough to generate enough power on solar panels?



- Primary Structure Material Usage – 6061-T6 aluminum is highly encouraged
  - Good strength/weight, readily available, affordable, relatively easy to machine, and DUCTILE (forgiving)
  - UNP11-9: Use a machined (milled), all-metallic primary structure
- Outgassing
  - Check ALL materials planned for use via <http://outgassing.nasa.gov/>
  - UNP11-28 specifies limits for outgassing (total mass loss and collectable volatile condensable material)
  - Certain metal coatings and “soft goods” (harness overwrap, plastic parts, adhesives) are main culprits
- Demiseability
  - Ensure the satellite burns up completely on entry into the Earth’s atmosphere
  - High melting point materials and large monolithic blocks of materials should be avoided



# Design

- The CAD model becomes the source for:
  - Geometry (all parts – assemblies – full vehicle)
  - Mechanical interfaces
  - Envelope (stowed for launch and deployed on orbit)
  - Mass properties (mass, center of mass location, moments of inertia)
  - Sensor and payload fields of view.

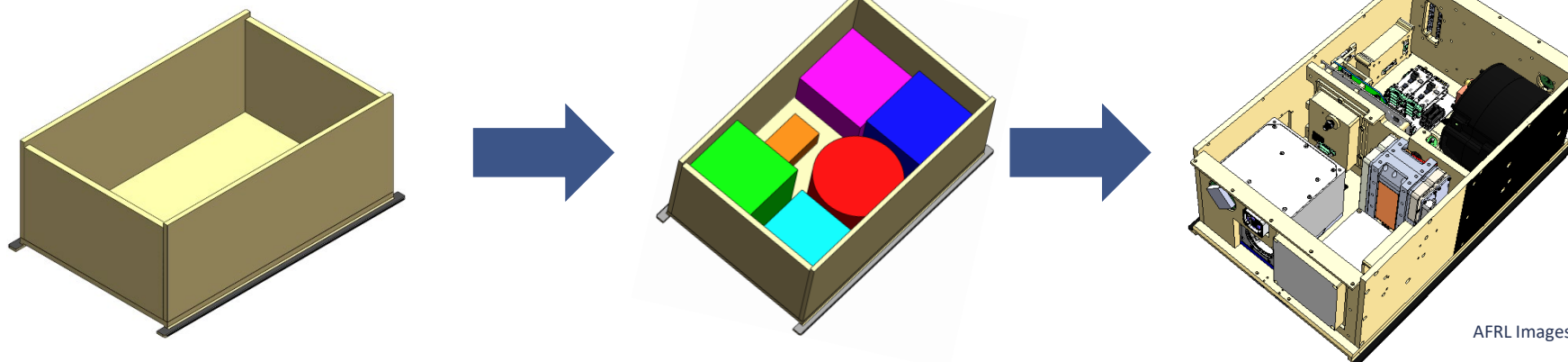

Building up the CAD is an iterative process



CAD model forms the basis for how parts/structure are fabricated and assembled.

- Perhaps the shop can fabricate parts directly from the CAD model
- Create drawings that include instructions for making piece parts
- Create assembly drawings that describe how parts come together (includes assembly plans)
- Establish a relationship with the people at the fabrication shop(s) you plan to use.
  
- *“You can’t design a part well if you don’t understand how it will be fabricated”*
- Assembly procedures help revise and update the model as necessary
  - 3D printed components and structure can inform assembly procedures
- In designing for assembly account for how satellite interfaces with MGSE, tool access, proper alignment, etc.

# UNP Types of Mechanisms/Deployables



- Moving Mechanical Assembly (MMA)
  - A device that controls the movement of a deployable or other movable system of a space or launch vehicle
- Why do mechanisms exist?
  - 1) Fit within launch vehicle or dispenser
  - 2) Stow for launch loads
  - 3) Change position or pointing once on orbit
  - 4) Deploy objects
- Mechanisms are not a required subsystem
  - Only use if absolutely necessary
  - Add risk to the mission

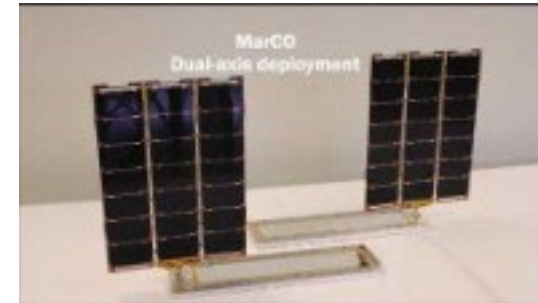

Solar Array



Boom

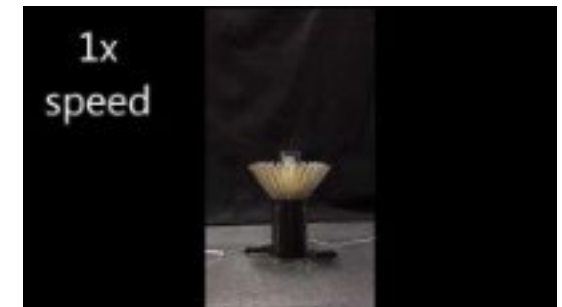

Antenna

NASA and Space Dynamics Lab Images

Questions to ask: “Do you really need a mechanism?” They add cost, schedule, and risk.

# UNP MGSE: CubeSat Lifting and Handling



- Mechanical Ground Support Equipment (MGSE) is too often a design afterthought.
- Brainstorm how your CubeSat will be handled, lifted, transported through entire life cycle
  - Example: The CubeSat will likely have to be rotated in order to insert it into the thermal vacuum chamber
- ID pick-up points; include in CAD model to avoid interference from other design features
- Ensure your lifting operations will be stable; avoid having the CubeSat CG elevated above the plane of lifting points
- Analyze MGSE with a FS=5 for ultimate failure (breaking, undue deflection)

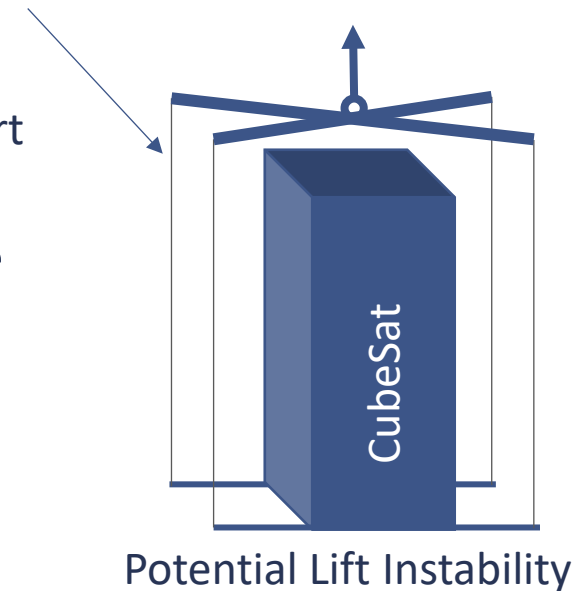



# Analysis and Testing



## Mass Budget

- Account for all of your components and structure and its material properties
- Mass = Current Best Estimate + Mass Contingency (% depends on design maturity)
  - Start with 25% contingency
- Make sure it is in the allowable mass range for CubeSats
  - 3U ~ 6kg, 6U ~ 12 kg, 12U ~ 24 kg

## Volume Budget

- Make sure all components can fit within the structure
  - 3U ~ 3,000  $cm^3$ , 6U ~ 6,000  $cm^3$ , 12U ~ 12,000  $cm^3$
- Estimate face occupancy (i.e., rough estimates of required placement for specific sensors)
  - A spacecraft with some solar panels, an antenna that must point at the ground to communicate, and a payload that looks at the earth horizon should orient these components on faces which normally point toward the desired target to minimize slewing.



UNP3: 30g applied independently in each axis

## Static Loads:

- Steady-state (thrust) and quasi-steady (wind gusts, engine staging events) acceleration.
- Expressed with “load factors”, or multiples of weight at sea level.

Focus on Structural Analysis

UNP4: Design to 15  $g_{rms}$  for one minute in each axis

## Random Vibration:

- The launch vehicle contractor defines a random vibration environment, stemming from the rocket engines, applicable to the interface between the LV and your CubeSat.

# UNP Structural Analysis Documentation



- UNP3 Can be verified via Structural Analysis
- Analyze to 30g on each axis of the structure
  - Added factors of safety and margin are not needed because it's already accounted for in the 30g itself
- UNP simplifies the analysis criteria by avoiding use of an added factor of safety above the 30-g load factor and does not distinguish between ultimate failure or detrimental yield.
- In order to get there:
  - State objectives and scope
  - Present an executive summary
  - List of applicable documents, drawings, and references
  - List requirements, criteria (analysis ground rules), and assumptions
  - List references to all supporting input data
  - Describe analysis methodology (geometry, materials, applied loads, boundary conditions, and assumptions)
  - List results and conclusions



# How is this actually tested? Plus, some others..



Mechanical Verification Testing – Vehicle Level		
Traditional* Test Flow	UNP Test Flow	Comment
Static Strength		UNP can impose a sine-burst test if deemed applicable.
Random Vibration or Acoustics	Random Vibration	Shaker table test for 1 minute in each orthogonal axis. CubeSats typically too small to respond to acoustics.
Modal Survey		Characterize modal response; validates the FEM. Instead, UNP determines fixed-base natural frequency while CubeSat is on the shaker table.
Mass Properties Characterization	Mass Properties Characterization	Measure mass, center-of-mass location, MOI; data used to validate the Solid Model and several other analyses.
Pyro-Shock		Avoiding pyro devices keeps shock environment benign. Analysis can be used to assess shock for sensitive items.
Bake Out	Bake Out	Draws out volatiles from soft goods and harness.
Thermal Cycle/Balance	Thermal Cycle	Exercise components through temperature extremes.
Thermal Vacuum	Thermal Vacuum	Most realistic simulation we have of the space environment.

\*Word “Traditional” applies to MicroSats/Large satellites, UNP is seen more broadly in CubeSats





# Thermal



- Introductions
- Work based on “Small Satellite Thermal Modeling Guide, Initial Release, July 2022”
  - Air Force Research Laboratory Space Vehicles Directorate (AFRL/RVSV)
- Purpose
  - Introduce methods/concepts to develop and analyze a small satellite thermal model
  - Understand why thermal modeling and thermal analysis are important
  - Understand common pitfalls
  - Learn about available resources

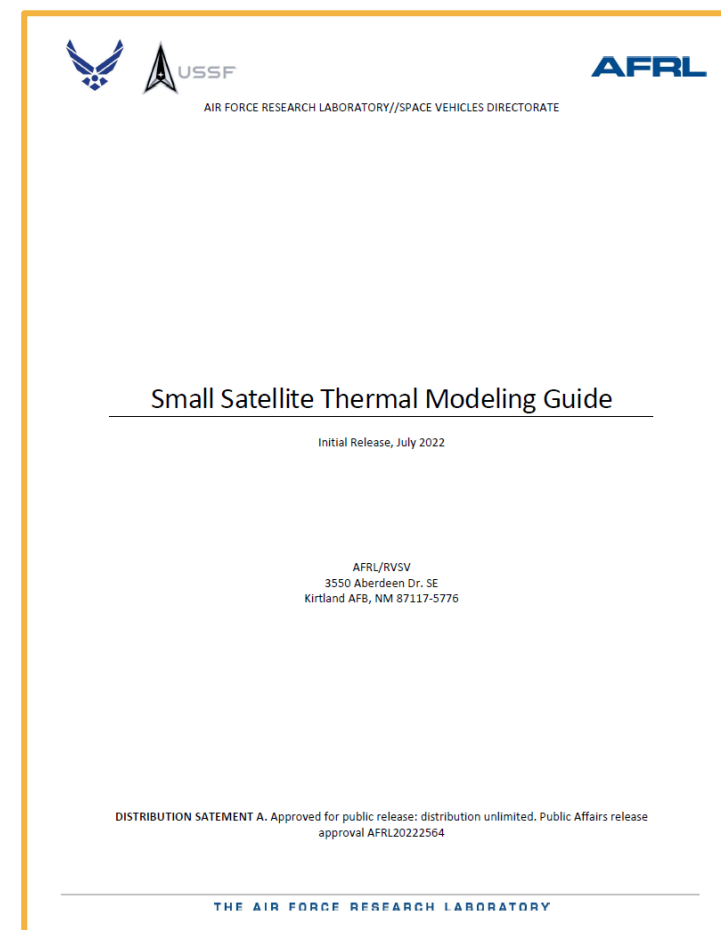

- Thermal subsystem is responsible for ensuring all hardware can operate within allowable thermal limits to achieve mission success
- How is this done? Through thermal modeling and testing
  - Good thermal design will meet these thermal limits
  - Must balance thermal design to meet power limits, as there's not unlimited power
- Thermal Design is an iterative, multi-disciplinary process
  - Thermal Modeling: process of capturing satellite's thermal characteristics
  - Thermal Analysis: process of simulating/analyze a thermal model
  - Good thermal model + good thermal analysis = good thermal design

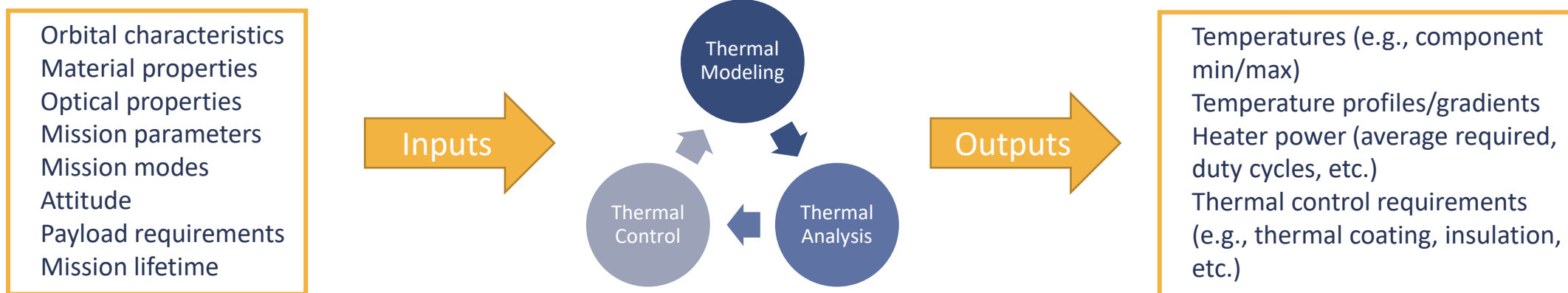

# UNP Review of Orbits



- Eccentricity ( $e$ ) – is the measure of how circular an orbit is
  - The orbit shown here displays an orbit with  $(e) = 0$  where the Apoapsis and Periapsis are equal

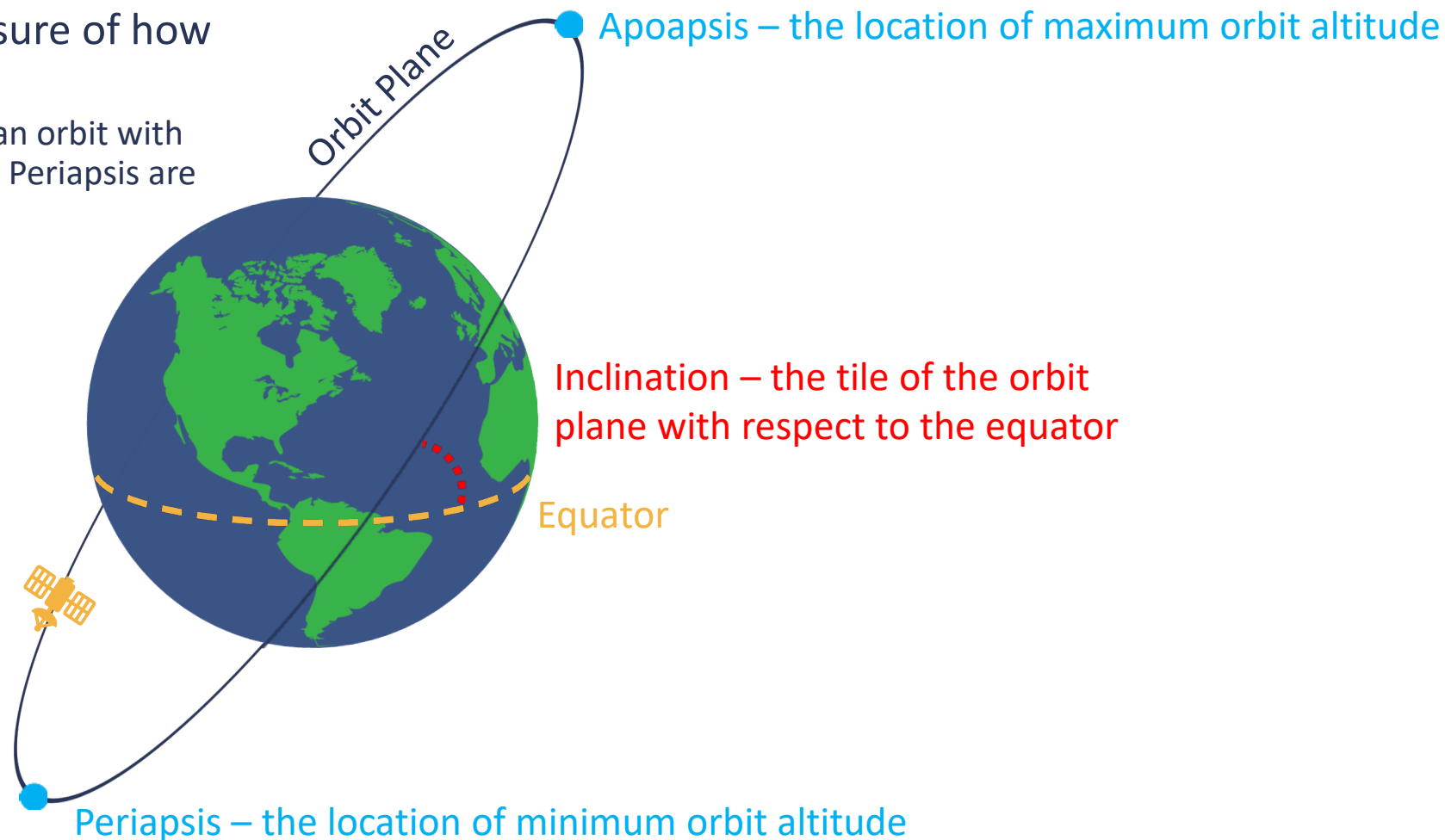

# UNP A New Variable: Beta Angle



- Beta Angle ( $\beta$ ) is the angle between the solar vector and its projection onto the orbit plane

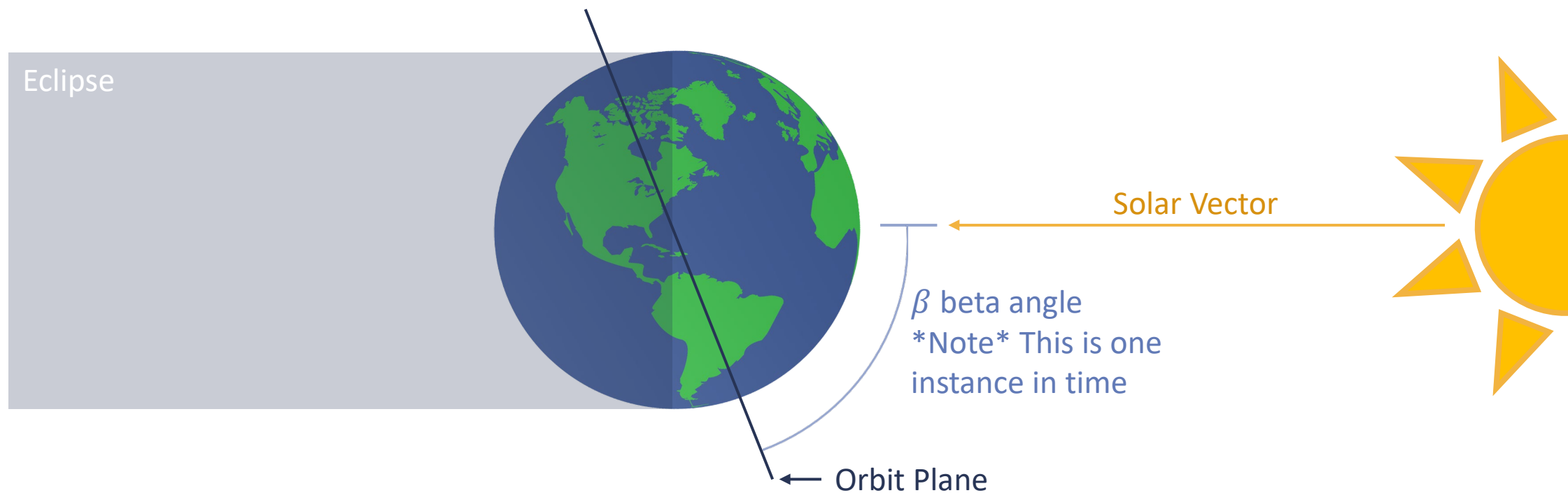

# UNP Beta Angle Variation



- Beta angle varies throughout the year at a given inclination
- Figure to the right shows a beta angle variation for an ISS orbit
  - This results in a  $\beta$  angle that varies between  $\pm 75.1^\circ$  over the course of a year
- Use beta angles to determine the coldest and hottest case the satellite will experience

Variation of the Beta Angle Due to Seasonal Variation and Orbit Precession

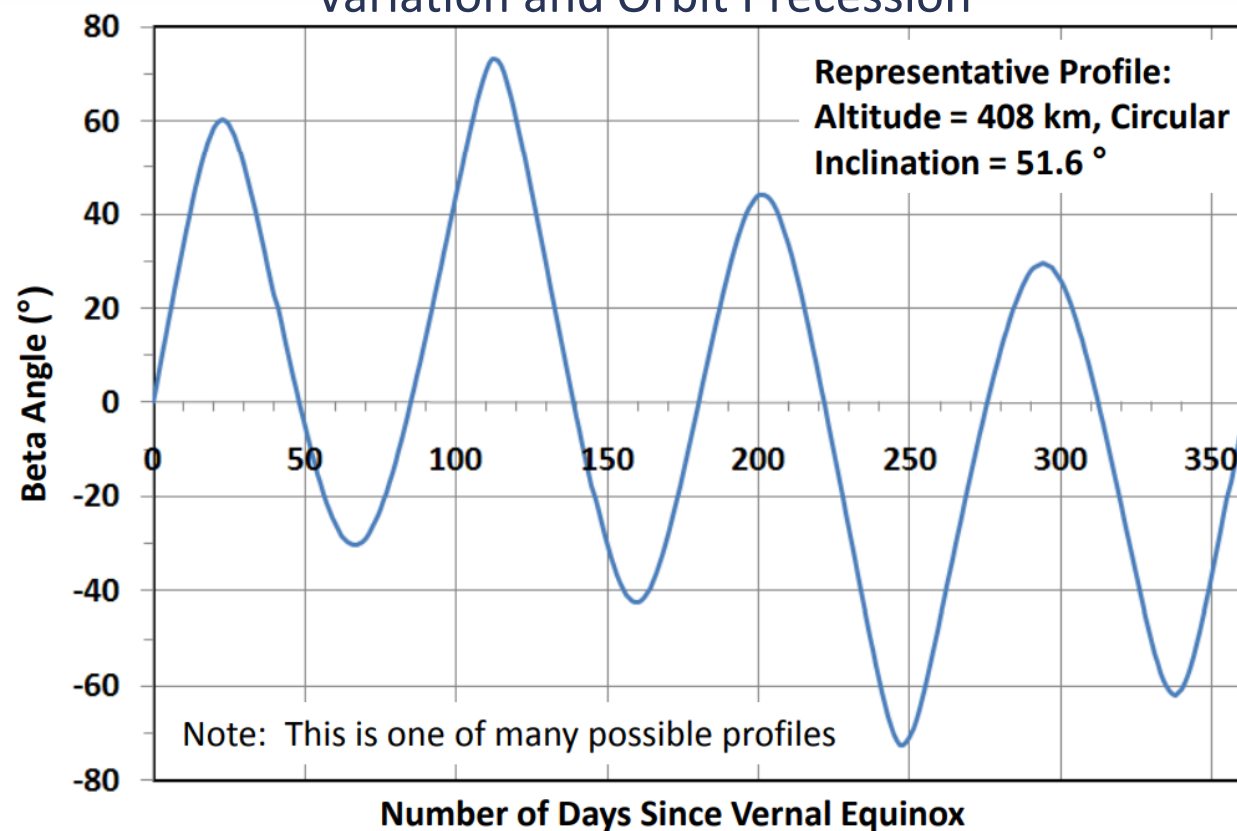

[https://tfaws.nasa.gov/wp-content/uploads/On-Orbit\\_Thermal\\_Environments\\_TFAWS\\_2014.pdf](https://tfaws.nasa.gov/wp-content/uploads/On-Orbit_Thermal_Environments_TFAWS_2014.pdf)

Cold Case:  $\beta = 0^\circ$



Satellite spends the most time in shadow  
- Polar orbit, launched at local noon or midnight

Hot Case:  $\beta = 90^\circ$

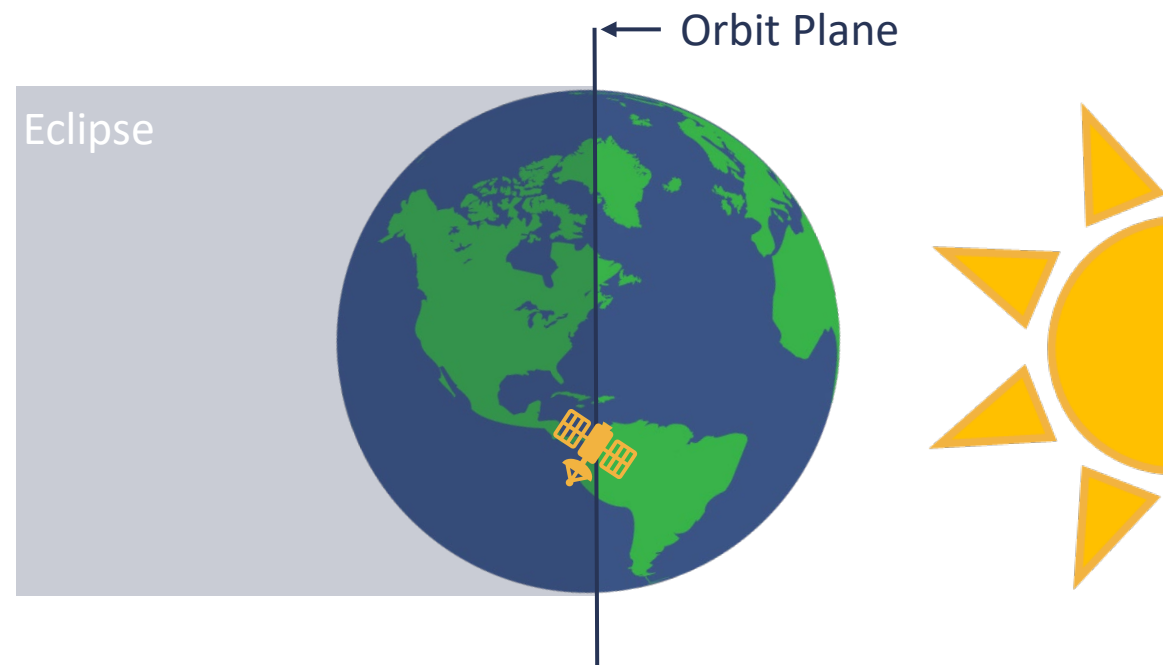

Satellite spends the most time in sun  
- Polar orbit, launched at local dawn or dusk

# UNP Review of Heat Transfer



- Conduction
  - Transfer of energy through direct (physical) contact
- Convection
  - Transfer of energy from a solid to adjacent liquid or gas in motion
- Radiation
  - Energy emitted by matter in the form of electromagnetic waves

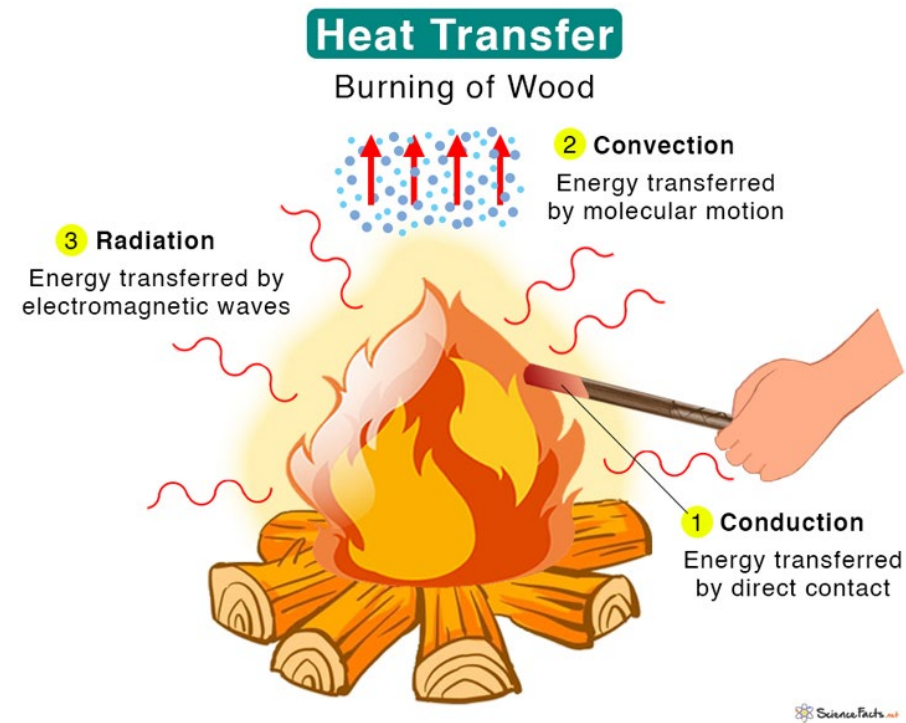

<https://www.sciencefacts.net/heat-transfer.html>

What forms of heat transfer does a satellite experience in space?

# UNP Orbital Thermal Environment

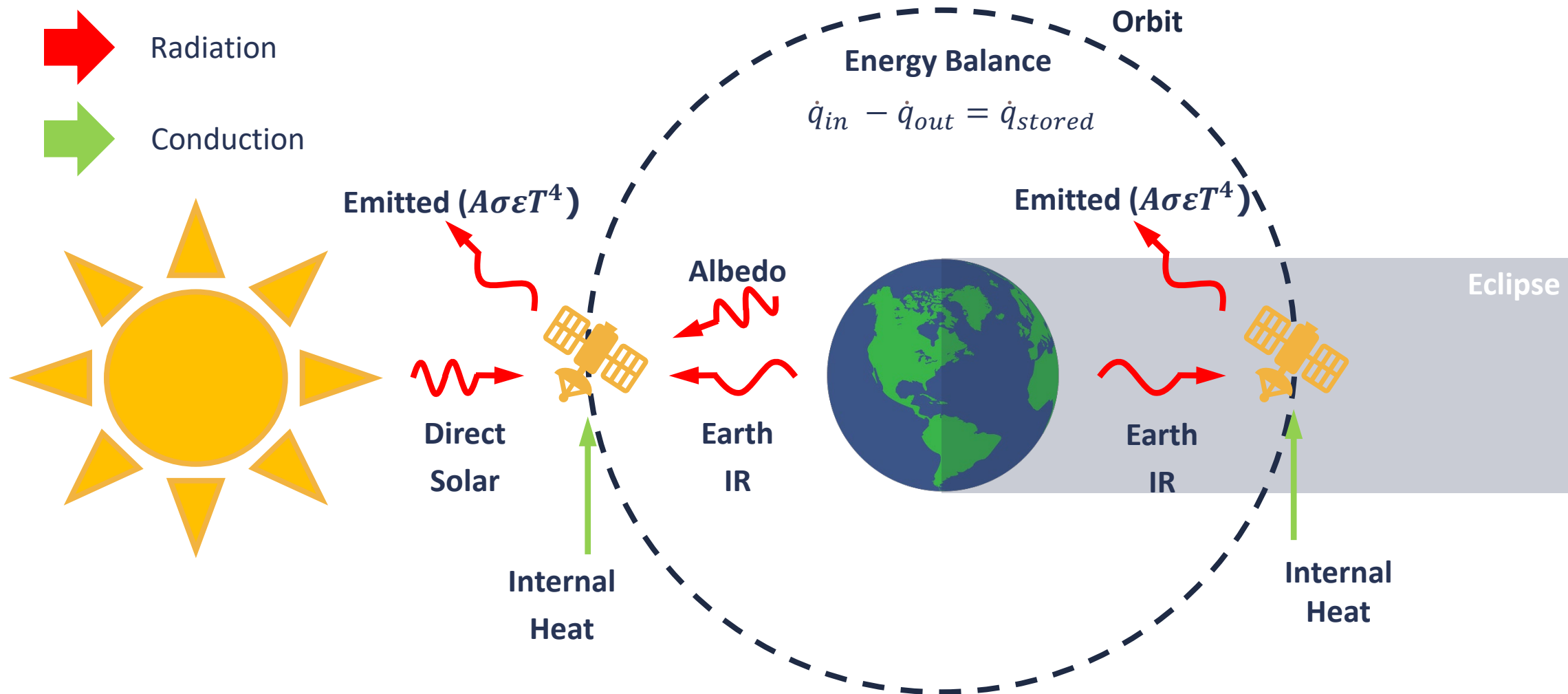

# UNP Governing Equation



- The thermal response of a satellite is governed by one equation:

$$\dot{q}_{in} - \dot{q}_{out} = \dot{q}_{stored} \text{ [W]}$$

- $\dot{q}_{in}$ 
  - $\dot{q}_{solar} = \alpha A S \cos\theta$
  - $\dot{q}_{albedo} = \alpha A S A_f F$
  - $\dot{q}_{IR \text{ flux}} = \varepsilon A S_{earth} F$
  - $\dot{q}_{in,generated}$ 
    - Heat generated from electronics. Refer to power budget for these values
- $\dot{q}_{out} = A \sigma \varepsilon T^4$
- $\dot{q}_{stored} = \rho C_p V \frac{\delta T}{\delta t}$ 
  - The thermal mass of a satellite describes the amount of heat the satellite can “store”

Variable	Unit	Description
$\alpha$	-	Absorptivity
$\varepsilon$	-	Emissivity
$A$	m <sup>2</sup>	Area of the surface
$S$	Wm <sup>-2</sup>	Solar Constant
$A_f$	-	Albedo Factor
$S_{earth}$	Wm <sup>-2</sup>	Earth IR Flux
$\theta$		Incident angle between solar normal vector and solar vector
$F$		View factor between satellite surface and Earth
$\sigma$	W m <sup>-2</sup> K <sup>-4</sup>	Stefan-Boltzmann Constant
$T$	K	Temperature of the surface
$\rho$	Kg m <sup>-3</sup>	Density
$C_p$	J kg <sup>-1</sup> K <sup>-1</sup>	Specific Heat
$V$	m <sup>3</sup>	Volume



- Understand and account for satellite:
  - Form factor (e.g. 3U, 6U, 12U)
  - Thermophysical properties: density, specific heat capacity, and thermal conductivity
  - Thermo-optical properties: absorptivity and emissivity

Material Property Table (\*not all encompassing)

Material	k [W/m/K]	$\rho$ [kg/m <sup>3</sup> ]	Cp [J/kg/K]	$\alpha$	$\epsilon$	References
Aluminum 6061-T6	167.9	2710	961	0.27	0.76	[1]
PCB - 4.6% Cu	18.04	2259.77	1544.11	0.74	0.88	[2]
PEEK	0.25	1300	1700			[3]
Solar Cells	60.6	5260	324	0.92	0.85	[4]

[1] D.G. Gilmore, *Spacecraft Thermal Control Handbook Volume 1: Fundamental Technologies*, El Segundo Boulevard: The Aerospace Press, 2002.

[2] K.E. Boushon, *Thermal Analysis and Control of Small Satellites in Low Earth Orbit*, Rolla: College of Engineering and Computing, Missouri University of Science and Technology, 2018.

[3] I. Foster, *Small Satellite Thermal Modeling Guide*, AFRL, 2022.

[4] "26.8% Improved Triple Junction (ITJ) Solar Cells," Spectrolab, 29 April 2008. [Online]. Available: <https://www.spectrolab.com/DataSheets/TNJCell/tnj.pdf>.



- Thermal modeling is the **process** of modeling a satellite's thermal characteristics using representative thermal geometry (e.g., surfaces and solids).
  - **IMPORTANT:** Thermal geometry and CAD geometry are not the same thing.
- Thermal modeling can be performed using hand calculations (e.g., Excel), programming language (e.g., Python, MATLAB), or appropriate thermal modeling software (e.g., Thermal Desktop)
- Characterize the inputs into the design
  - Mission Modes – What is the cold case? What is the hot case?
  - Orbit – What is the orbit in each thermal case?
  - Material Properties – thermophysical/thermo-optical properties
  - Geometry and Heat Flow Paths – Satellite Structure, Component Geometry, and how they're connected thermally
  - Heat Loads – Heat generation from hardware and electronics. Refer to power budget
  - Etc.

# UNP Thermal Modeling Process

## Thermal Nodes



**Thermal Node:** The fundamental building block of a thermal model

- Thermal nodes store energy, which is represented by temperature
- Thermal geometry (e.g., thermal surfaces and solids) contain thermal nodes.
- Thermal networks are a collection of thermal nodes and thermal objects linked together by radiation and/or conduction

**IMPORTANT:** Everything that a thermal node represents will have the same temperature as that node. If you model an entire component with only one node, then that entire component will have the temperature of that node in your thermal model.

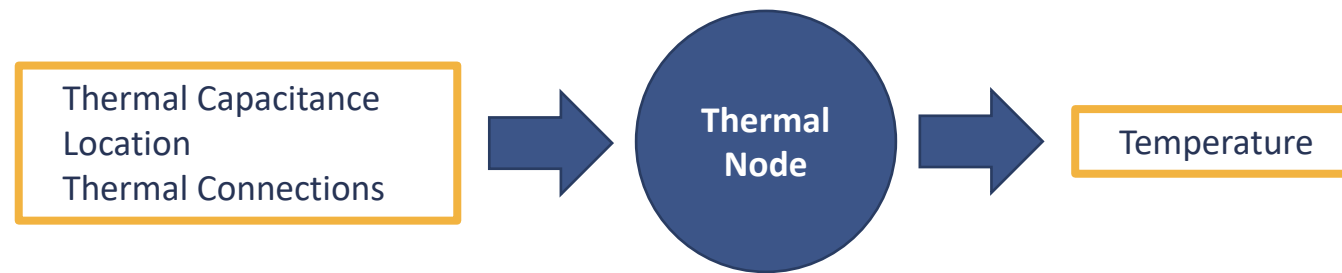

# UNP Thermal Modeling Process

## Fidelity, Accuracy, and Resolution



- **Fidelity:** Describes correspondence with reality. **Geometric fidelity** describes to what degree a thermal model's thermal geometry corresponds to physical geometry (i.e., CAD Model).
  - Driven by accuracy requirements
  - Driven by thermal characteristics
- **Accuracy:** Is a measure of how well the model represents reality.
  - Driven by component/mission requirements
  - Limited by resolution
- **Resolution:** To what degree of precision results are known. Functionally equivalent to number of thermal nodes.
  - Driven by accuracy requirements
  - Driven by thermal characteristics
  - Informed by geometric fidelity (i.e., how component is modeled)

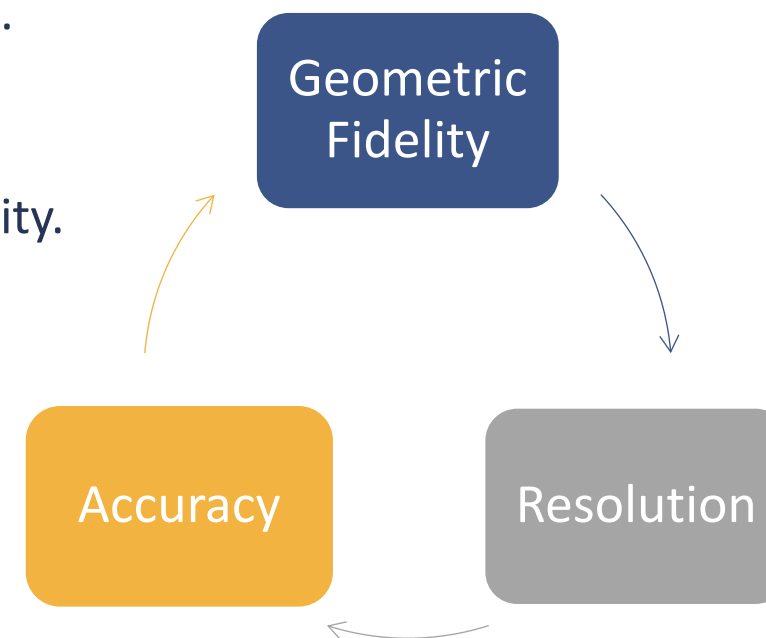

Thermal Geometry and CAD Geometry are NOT the same thing

# UNP Thermal Modeling Process

## Demonstration of Fidelity, Accuracy, and Resolution



- The CAD model of an ISISPACE bracket (left) is converted into a thermal model (right).
- The results remains nearly identical for all four thermal models.
- **IMPORTANT:** A thermal model can be very accurate without having high geometric fidelity

Decreasing Geometric Fidelity →

Decreasing Resolution

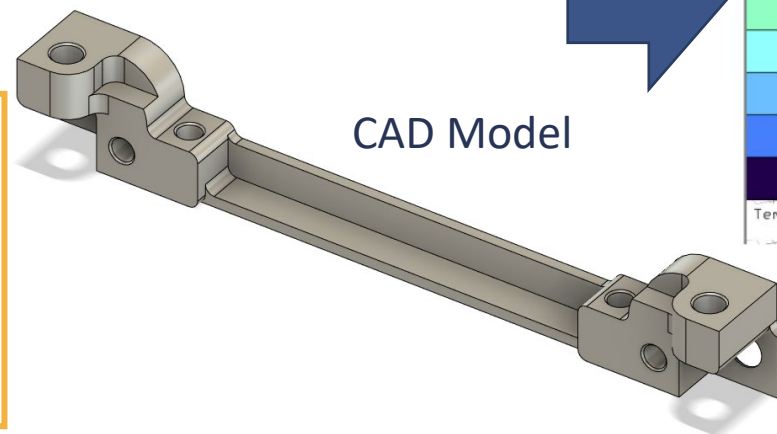

CAD Model

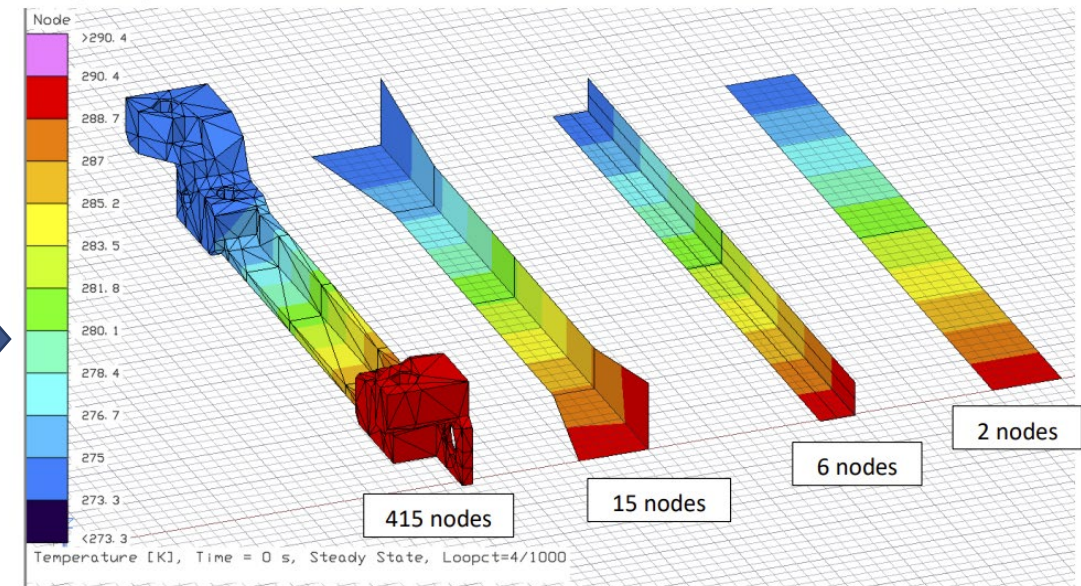

Thermal Model

**USE CORRECT  
NUMBER OF NODES!**

Too many = slow  
model; not enough =  
poor predictions



Component	Consideration	Possible Solution
Batteries	Have a high minimum operating temperature ( $\sim 0^{\circ}$ - $10^{\circ}$ ) i.e. they get cold	Most batteries come with heaters already installed
Transmitters	Have high power draws i.e. they get hot. Consider duty cycle	Passive thermal control* (thermal straps)
Processors	Have high power draws i.e. they get hot. Consider duty cycle	Passive thermal control* (thermal straps)

\*This doesn't mean every transmitter or processors needs thermal control

