

# UNIP



## Licensing, Policy, and Launch/Range Safety



**Exploration Research and  
Technology Programs**





# Range Safety and Design

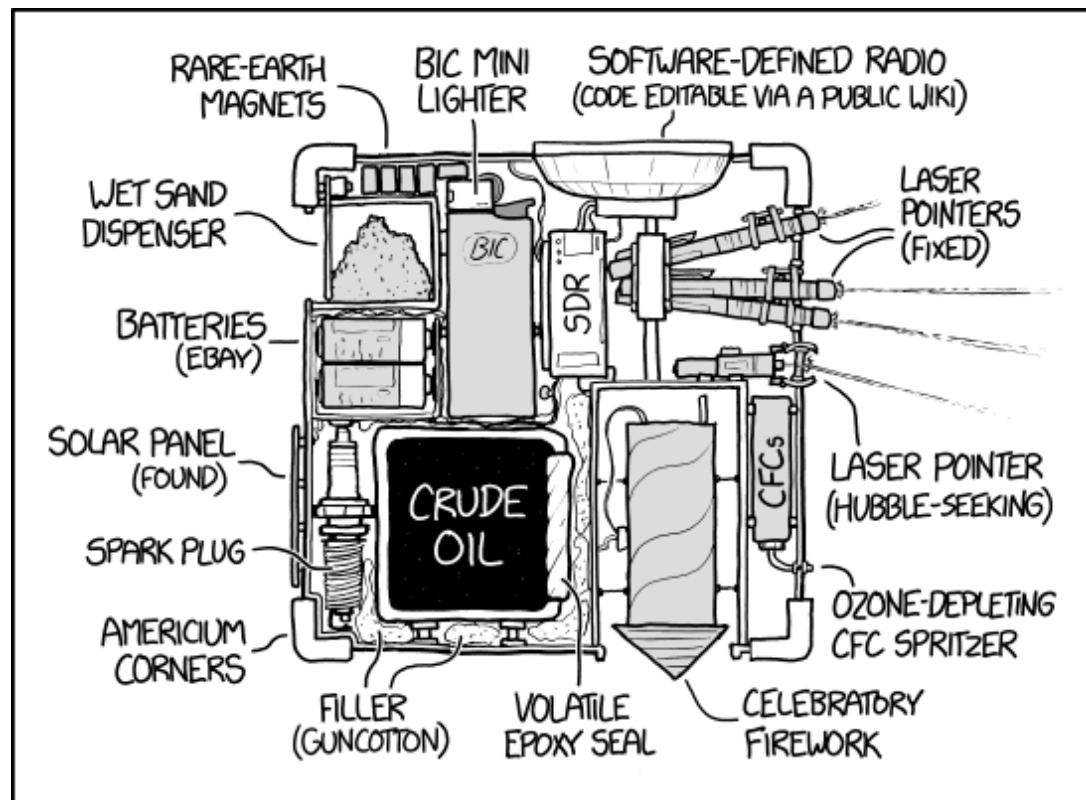

MY CUBESAT PROPOSAL WAS THE FIRST TO BE REJECTED FOR VIOLATING EVERY DESIGN AND SAFETY REQUIREMENT SIMULTANEOUSLY.

Credit: <https://xkcd.com/1992/>

- Design to make licensing and launch easy
  - Sometimes the most innovative or elegant solution isn't the best one
  - The less you have to prove, the better
    - Don't use novel materials
    - Don't use novel methods
- Example: 3D printing is cool and reduces part count because you can design otherwise unmachinable parts
  - Now you have to test, analyze, and prove to everyone that your part won't fail
  - If you machined the parts from AL 6061-T6 and bolted them together with stainless steel fasteners, nobody would have looked twice



## Ensure your satellite will be accepted for launch by a launch vehicle (LV) provider

- Meets do-no-harm criteria
- Meets deployer criteria

## Keep launch options open when it comes time to manifest

- Common launch-vehicle needs
- CubeSat best practices

## Provide context for many of the UNP requirements

- We promise we didn't make them up
- Also, waivers



## Launch/Range Safety

- Proving you will not induce harm on people and other systems on the ground or on the rocket

## On-Orbit Safety

- Proving you will survive the launch environment and that you will not do harm in space

There are various types of requirements that apply to you (or anyone wanting to launch a CubeSat)

# UNP Launch Requirement Types



Range Safety

On-Orbit Safety

Common/Global Spacecraft Requirements

Get-out-of-requirements through CubeSat Requirements

Launch Specific Requirements

UNP Requirements are provided to you to cover all types of requirements

# UNP Launch Requirement Type Examples



- There are different categories of requirements that apply to you (or anyone wanting to launch a CubeSat)

## Range Safety

Two-Fault Tolerance (AFSPCMAN 91-710)

Reduced Requirements Subset

Integration specific requirements

## On-Orbit Safety

5 year deorbit/disposal

Dispenser compliance

Vibration Levels

# UNP So how do I get ready for launch now?



## Known Dispenser Interface

- Follow your Dispenser ICD!
- Literally the reason CubeSats were invented

## UNP User's Guide

- We wrote this for this reason!
- This is the SparkNotes version!

## If you're doing something weird, look into it

- Ask UNP/CSLI
- Look up NASA specs (but be careful about interpreting/applying them to CubeSats without an expert)

## Keep your options open

- Try not to lock yourself in to a specific type of launch
- But if you have to, think it through



- NanoRacks CubeSat Deployer ICD (NRCSD ICD): Safety and interface standards for CubeSats deploying from the International Space Station. Due to the stringent human-safety requirements of the ISS, CubeSats meeting NRCSD safety requirements will meet safety requirements for all launches
- AFSPCMAN 91-710: Commonly referred to as the MSPSP
- NASA General Environmental Verification Specification (GEVS) (GSFC-STD-7000A): General environmental test standards for satellites. Written for large satellites so does not always apply to CubeSats
- Various launch vehicle ICDs or payload user guides
- Various NASA and Air Force standards
- AFRL/RVEN (Small Satellite Portfolio and University Nanosatellite Program) experience
- NASA CSLI Requirements

Requirements set was designed for both external regulation (i.e. launch safety) AND best practice (for you)

# UNP Structural Design for Launch (In Addition to Safety)



- Deployer choice
  - Calpoly CubeSat Design Specification keeps deployer options open
  - Others will make launch more difficult from the start
    - Only choose them with good reason
    - Discuss those reasons with UNP/CSLI
- Pressure vessels
  - Discuss with UNP/CSLI if you intend to fly a pressurized system
- Sealed systems/Passive Venting: Ensuring pressure release as launch vehicle ascends
  - COTS components can be sneaky: i.e. space between lenses in COTS lens assembly

# UNP Electrical Design for Launch: Inhibits



- Prevent hazardous events from occurring
  - RF transmission
  - Satellite power-on
  - Mechanical impact such as deployments (antennas, panels, etc.)
  - Fire/explosion/battery runaway
  - Corrosive material accumulation
- In UNP-speak, inhibits are seen in:
  - Power system: Battery and solar panels must be inhibited during launch
  - Fluid management (propellant): No leaks may occur
- Must be two-fault tolerant
  - One switch isn't enough as a single failure could allow hazardous event to occur
  - Any hazardous operation must be inhibited such that two or fewer faults can occur and the system will stay inhibited. I.e. three switches in series
  - Applies to entire inhibit system. I.e. power FETs AND activation/gate drivers for them, not just the FETs

# UNP Recommended Inhibit Architecture



## Activation chain:

Mechanical switches depressed by satellite sitting inside deployer. Creates low voltage/current enable signal

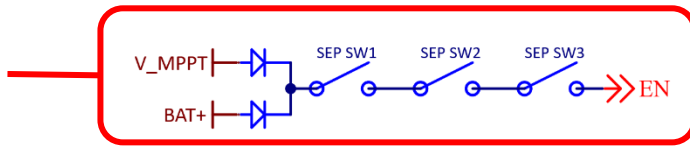

## Low-side inhibit:

Single FET with gate driver. Note FET type differs from high side inhibits

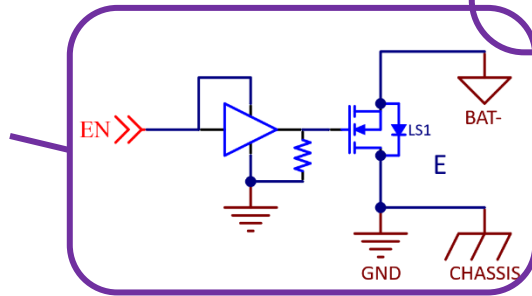

## Solar panel inhibits:

Note three high side inhibits in series (plus IBF/RBF) between solar panels and load

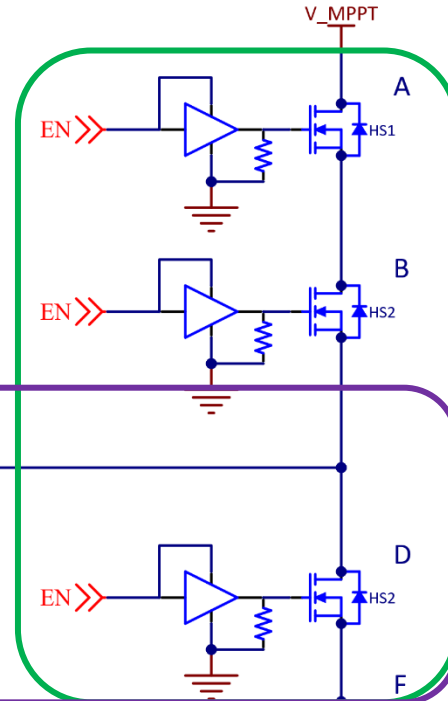

## Battery inhibits:

Note two high plus one low inhibits (plus IBF/RBF) between battery and load

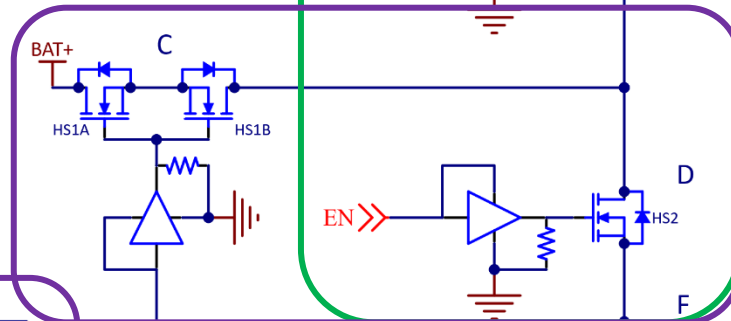

## IBF/RBF

Install/Remove before flight inhibit provides easily human-controlled switch for easy disabling of system

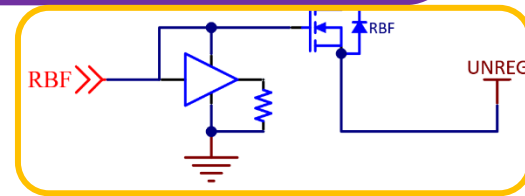



- Many COTS options available for CubeSats
  - Ensure Inhibit architecture meets UNP requirements. If not, custom inhibits must be inserted into circuit
- If building your own pack, ensure the following:
  - Cells are Underwriters Laboratory (UL) approved
  - Cells have United Nations Transportation Certificate
  - If these are not met, there is a long list of tests that must be performed to appease range safety
- Keep pack capacity under 80 Wh
  - ISS safety requirement
  - Waivable by UNP/CSLI with good reason and possibly some mitigating design work



Cubesat Design Specification Rev 14.1 refers to AFSPCMAN 91-710 Volume 3

## Severity categories defined within MIL-STD-882

- 3.2.1 If a system failure may lead to a catastrophic hazard, the system shall have three inhibits (dual fault tolerant).
- 3.2.2. If a system failure may lead to a critical hazard, the system shall have two inhibits (single fault tolerant).
- 3.2.3. If a system failure may lead to a marginal hazard, the system shall have a single inhibit (no fault tolerant).

SEVERITY CATEGORIES		
Description	Severity Category	Mishap Result Criteria
<b>Catastrophic</b>	<b>1</b>	Could result in one or more of the following: death, permanent total disability, irreversible significant environmental impact, or monetary loss equal to or exceeding \$10M.
<b>Critical</b>	<b>2</b>	Could result in one or more of the following: permanent partial disability, injuries or occupational illness that may result in hospitalization of at least three personnel, reversible significant environmental impact, or monetary loss equal to or exceeding \$1M but less than \$10M.
<b>Marginal</b>	<b>3</b>	Could result in one or more of the following: injury or occupational illness resulting in one or more lost work day(s), reversible moderate environmental impact, or monetary loss equal to or exceeding \$100K but less than \$1M.
<b>Negligible</b>	<b>4</b>	Could result in one or more of the following: injury or occupational illness not resulting in a lost work day, minimal environmental impact, or monetary loss less than \$100K.

<https://www.dau.edu/cop/armysoh/DAU%20Sponsored%20Documents/MIL-STD-882E.pdf>

Rockets are filled with expensive satellites (more than \$10M) and highly risk averse, you're in category 1



- Counts as an inhibit
  - Solenoid, Latching, or Pressure Relief Valves
  - Dual seat valves may count as two inhibits
  - Leak-tight End Caps
- Does not count as a prop inhibit
  - Check valves
  - Electrical inhibits (possibly some flexibility here, but not always an option)
- System leak and proof testing is also key. Section 12.3 of 91-710 has guidance on pressure vessel design, analysis, and test requirements

# UNP Additional Launch Safety Considerations



- Hazardous Operations Timer: After inhibits close, allowing satellite activation, system must still wait a TBD amount of time before RF transmission, deployable release, etc.
  - Typically 30-45 minutes
  - Design to be software configurable
- Material selection
  - Fully demisable on reentry
  - Analyze with NASA Debris Assessment Software (DAS)
  - Orbital Debris Analysis Report (ODAR) necessary for FCC licensing
- Orbit design
  - High enough to survive for the length of the mission
  - Low enough to come down within 5 years



- UNP list of requirements is minimized as much as possible
- If a UNP requirement cannot be met, contact UNP
- Must have good reason to request a waiver, and must be able to justify it
  - UNP will handle on a case by case basis
  - Very few requirements are waivable, in part or whole
- CSLI may also waive their requirements
  - Contact CSLI for this

Requirements are there for a reason, and some of the reasons may be unclear. Contact experts



# Licensing and Coordination

# UNP Satellite Frequency Licensing 101



- You need to communicate with your satellite
- Radio frequencies are the only viable approach for TT&C
- You need a license to operate any transmitter (few exceptions)
- The launch provider will not let you on the rocket without a license
- The licensing process is opaque and takes time to understand
- There are many other stakeholders involved
- Your satellite will operate outside the United States, requiring international coordination
- The regulations are evolving

# UNP The Electromagnetic Spectrum



## Satellite Frequencies

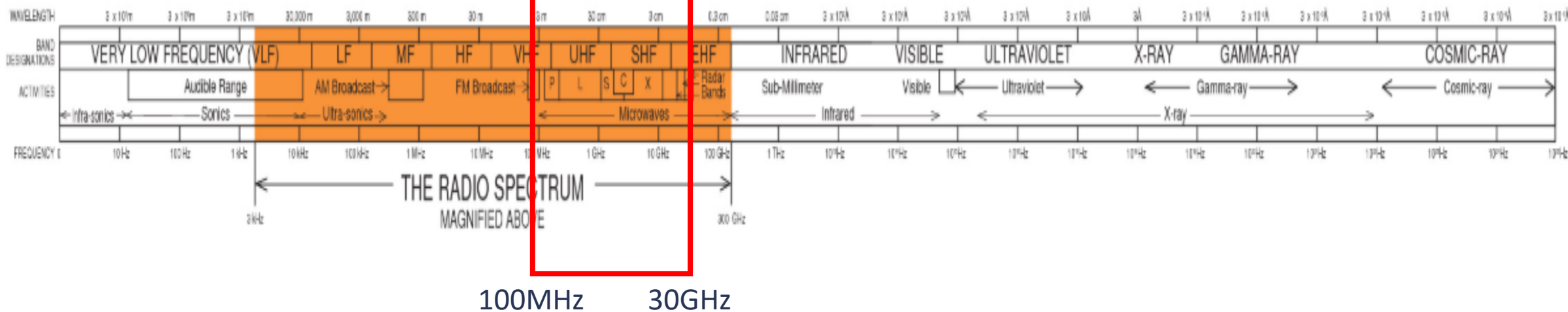



- Coordination is how frequency bands are allocated based on interference, needs, and ownership
  - For example, being granted an allocation in amateur radio bands would be a form of coordination. This letter of coordination is then brought to the FCC who can grant the license
  - Finding your own available bands is possible but difficult without expertise. Hiring an expert to help with coordination and licensing is well worth it. Many gotchas.
- Licensing is the government providing you authorization to transmit/perform some activity
- Two US licensing agencies
  - FCC: All non-government-owned entities go through FCC
  - NTIA: Government-owned entities go through NTIA
    - This is not you. Even though you may be heavily funded by NASA or the DoD, your satellite is university-owned, and therefore must go through the FCC. UNP cannot directly intervene on your behalf, and you should avoid causing confusion in this regard. Teams that have confused the FCC and NTIA about ownership have been completely stuck when neither agency would take them.
- Regardless of coordination method/organization, all satellites must have a license

Some examples of a first step in finding available bands are shown in the next slides. All reference the US Spectrum Management Chart: [en.wikipedia.org/wiki/Spectrum\\_management](https://en.wikipedia.org/wiki/Spectrum_management)

# UNP UHF Spectrum (US)



399.9  
400.05  
400.15  
401.0  
  
402.0  
403.0  
406.0  
406.1  
  
410.0  
420.0  
  
450.0  
454.0  
455.0  
456.0  
  
460.0  
462.5375  
462.7375  
467.5375  
467.7375  
470.0

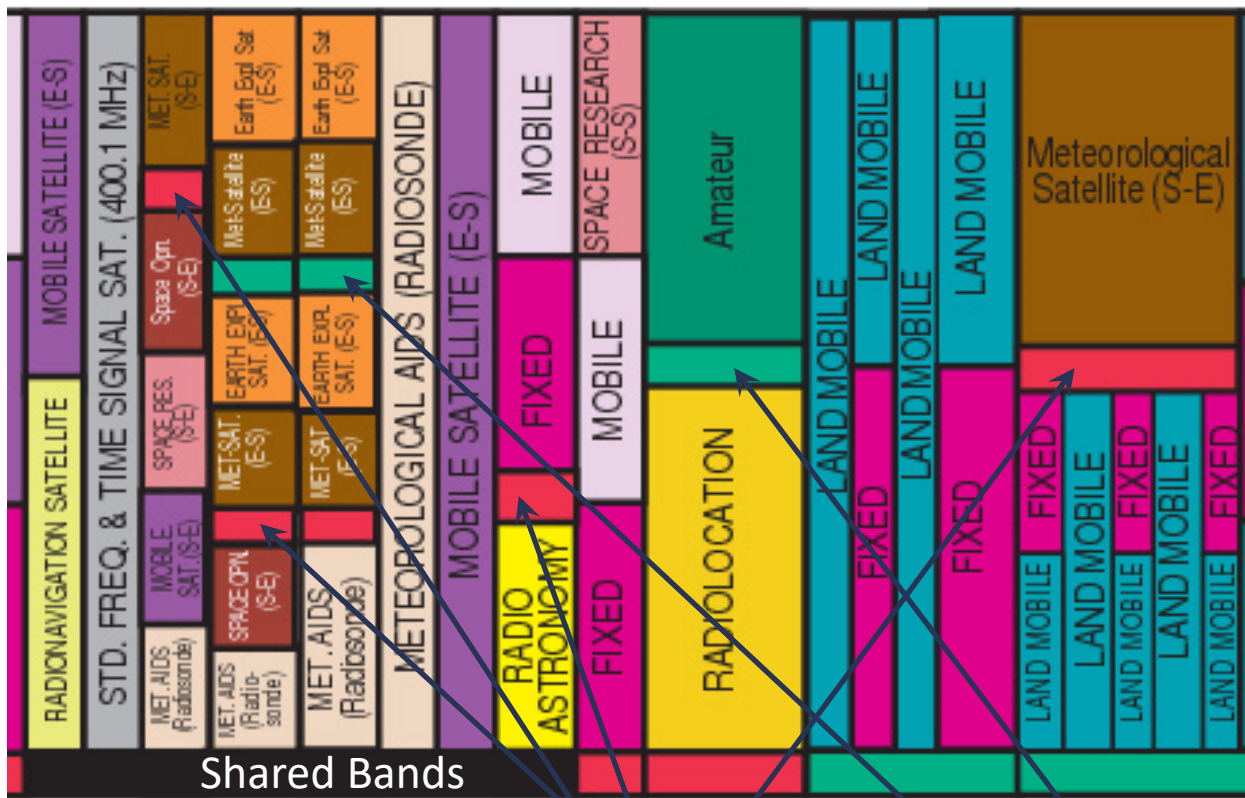

Shared Bands

GOVT NON-GOVT

400.15-401MHz (downlink)

- METSAT (SE)
- Space OP (SE)
- Space Res (SE)
- Radiosondes!!

400.1-403MHz (uplink)

- EESS (ES); EESS (ES)
- METSAT (ES); METSAT (ES)
- Space OP (SE)
- Radiosondes!!
- GOES IOT monitors

410-420 MHz (crosslink)

- SRS (SS)

420-450MHz

- Amateur
- ITU foot note 5.282 – 435-438MHz the amateur-satellite service may operate subject to not causing harmful interference to other services.

450 MHz

- US footnote US87 The band 449.75-450.25 MHz may be used by Federal and non-Federal stations for space telecommand (Earth-to-space) at specific locations, subject to such conditions as may be applied on a case-by-case basis. Operators shall take all practical steps to keep the carrier frequency close to 450 MHz.

460-470 MHz (downlink)

- METSAT (SE) – US201 In the band 460-470 MHz, space stations in the **Earth exploration-satellite service** may be authorized for **space-to-Earth** transmissions on a secondary basis with respect to the fixed and mobile services. When operating in the meteorological-satellite service, such stations shall be protected from harmful interference from other applications of the Earth exploration-satellite service. The power flux-density produced at the Earth's surface by any space station in this band shall not exceed **-152 dBW/m<sup>2</sup>/4 kHz**. USU CADET-U operates in this band.

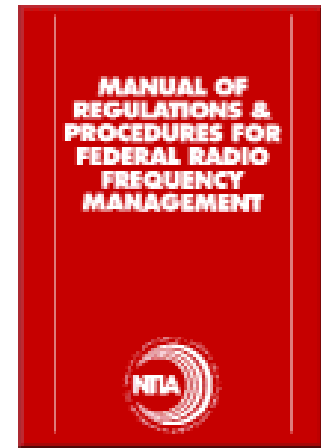



# UNP X-Band Spectrum (US)



7.145	FIXED	SPACE RESEARCH (deep space)(Earth-to-space)	FIXED
7.19	FIXED	SPACE RESEARCH (Earth-to-space)	FIXED
7.235	FIXED		FIXED
7.25	FIXED-SATELLITE (space-to-Earth)	MOBILE-SATELLITE (space-to-Earth)	FIXED
7.3	FIXED-SATELLITE (space-to-Earth)	Mobile-satellite (space-to-Earth)	FIXED
7.45	FIXED-SATELLITE (space-to-Earth)	METEOROLOGICAL SATELLITE (space-to-Earth)	FIXED
7.55	FIXED-SATELLITE (space-to-Earth)	Mobile-satellite (space-to-Earth)	FIXED
7.75	METEOROLOGICAL-SATELLITE (space-to-Earth)	FIXED	FIXED
7.85	FIXED		FIXED
7.9	FIXED		FIXED
8.025	FIXED-SATELLITE (Earth-to-space)	MOBILE-SATELLITE (Earth-to-space)	FIXED
8.175	EARTH EXPLORATION-SATELLITE (space-to-Earth)	FIXED SATELLITE (Earth-to-space)	FIXED
8.215	METEOROLOGICAL-SATELLITE (space-to-Earth)	EARTH EXPLORATION-SATELLITE (space-to-Earth)	Mobile-satellite (Earth-to-space) (no airborne)
8.4	FIXED	SPACE RESEARCH (deep space)(space-to-Earth)	FIXED
8.45	SPACE RESEARCH (space-to-Earth)		FIXED
8.5	RADIOLOCATION		RADIOLOCATION

- 7145-7190 MHz (uplink)
    - SRS (ES) – deep space
  - 7190-7235 MHz (uplink)
    - Space Res (ES)
  - 7450-7550 MHz (downlink)
    - METSAT (SE)
      - ITU 5.461A The use of the band 7450-7550 MHz by the meteorological-satellite service (space-to-Earth) is limited to geostationary-satellite systems.
  - 7750-7850 MHz (downlink)
    - METSAT (SE)
      - ITU 5.461B The use of the band 7750-7850 MHz by the meteorological-satellite service (space-to-Earth) is limited to non-geostationary satellite systems.
  - 8025-8175 MHz (downlink)
    - EESS (SE)
      - US258 In the bands 8025-8400 MHz and 25.5-27 GHz, the Earth exploration-satellite service (space-to-Earth) is allocated on a primary basis for non-Federal use.
  - 8175-8215 MHz (downlink)
    - METSAT (SE)
    - EESS (SE)
  - 8215-8400 MHz (downlink)
    - EESS (SE)
  - 8400-8450 MHz (downlink)
    - SRS (SE) – deep space
    - SRS (SE) – deep space
  - 8450-8500 MHz (downlink)
    - SRS (SE)
      - Note that NASA and other international agencies are using this band for lunar exploration
- EESS X-band downlinks are used extensively for NASA and commercial Earth remote sensing missions. Licensing in these bands needs to be coordinated with NASA. SRS deep space bands have significant keep out requirements which require sharp filters if operating in neighboring bands.

# UNP Frequency Licensing Considerations



- Must be coordinated to avoid interference
- Must be able to shut off transmitter
- Cannot claim protection from interference
- Amateur links cannot be obscured and packet definitions must be posted. (exception for command uplink)
- NOAA will require encryption for Earth observations. This creates a challenge with using the Amateur bands for downlinking Earth observing data.
- UHF bands are typically limited to 10-20kHz bandwidth

# UNP Other Considerations/Requirements



- Imaging: National Oceanic and Atmospheric Administration (NOAA) Earth Imaging License
- Lasers
  - Laser Clearing House (LCH)
  - Federal Aviation Administration (FAA)
- Deorbit requirements
  - Must show zero risk of casualty (fully burn up)
    - Use NASA Debris Assessment Software (DAS) – widely accepted for modeling this
  - Deorbit within 5 years of end of mission
    - Applies to satellites below 2000km altitude
    - New regulation replaced 25-year rule in fall 2022
    - Some lack of clarity on what defines “End of mission”
- Start licensing early. Some of these take extensive amounts of time (over a year)

